

Sponde Metalliche SLIM ammortizzate - H.84
SLIM Metal Boxes with Soft-Closing - H.84

Specifiche

Estrazione: Totale sincronizzata
Chiusura: Ammortizzata
Portata: 45 Kg
Durata: Oltre 50.000 cicli
Finitura guida: Zincata

Specifications

Extention: Full Synchronized
Closing: Soft
Load Rating: 45 Kg
Cycling: Over 50.000 times
Slide Finishing: Galvanized

Finitura sponda Slim box finishing

■ Grigio antracite	Dark grey
■ Grigio chiaro	Light grey
□ Bianco	White

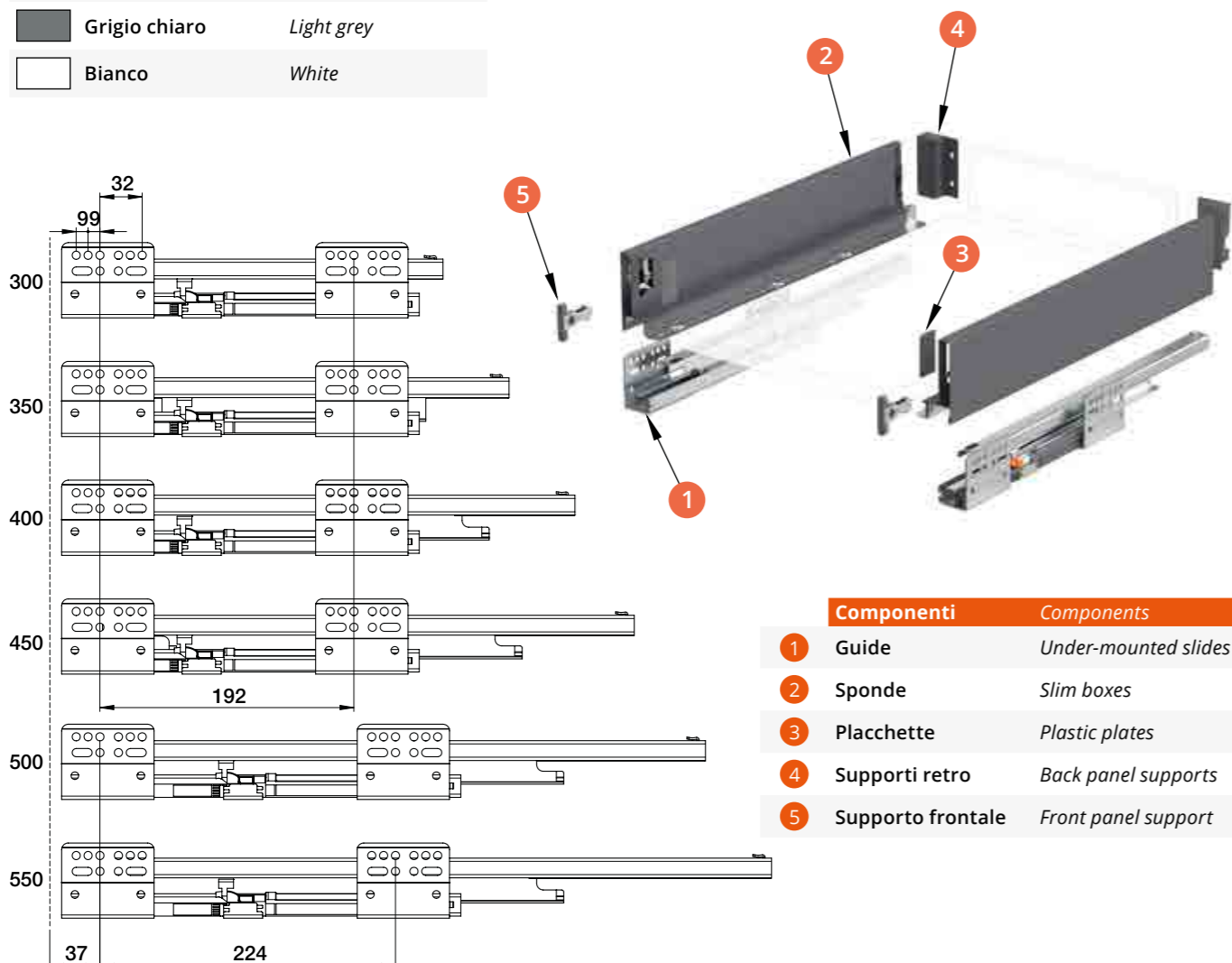

Componenti Components

1	Guide	Under-mounted slides
2	Sponde	Slim boxes
3	Placchette	Plastic plates
4	Supporti retro	Back panel supports
5	Supporto frontale	Front panel support

Dimensioni per montaggio frontale
Drawer front panel assembling diagram

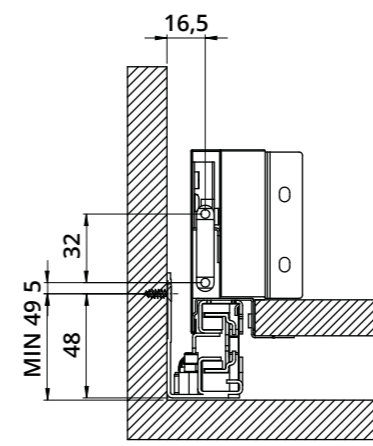

Vista frontale / Front view

Dimensioni ingombro cassetto e retro
Drawer and back panel overall dimensions

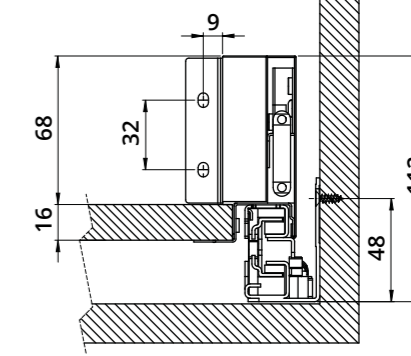

Vista retro / Back view

Dimensioni fondo e retro
Bottom and back panel dimensions

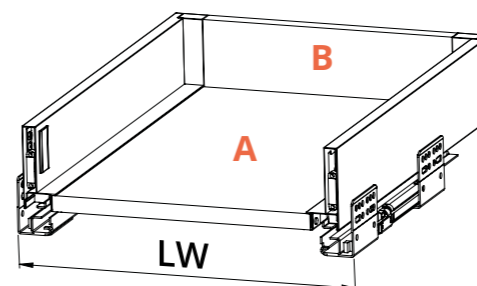

LW=Larghezza interna mobile
LW=Cabinet inner width

Fondo / Bottom panel

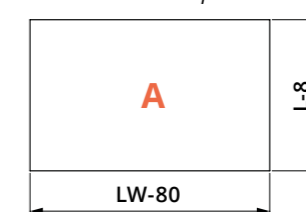

Retro / Back panel

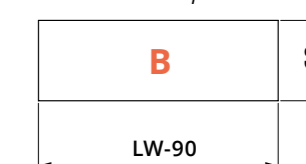

Pannello spessore: 16 mm
Panel thickness: 16 mm

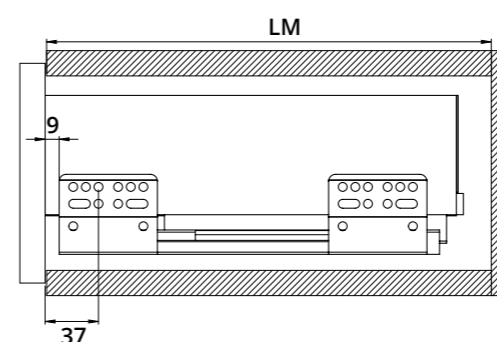

Foratura fianco con frontale a battuta
Side panel hole drilling with outer drawer front

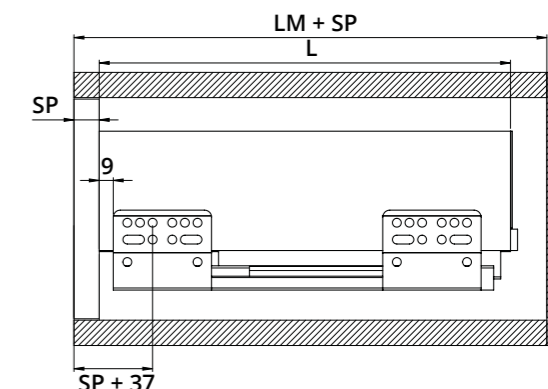

Foratura fianco con frontale interno
Side panel hole drilling with inner drawer front

Codice Code	Finitura sponda Slim box finishing			L	LM
SP-SL-84 L 30 -	■	■	□	300	310
SP-SL-84 L 35 -	■	■	□	350	360
SP-SL-84 L 40 -	■	■	□	400	410
SP-SL-84 L 45 -	■	■	□	450	460
SP-SL-84 L 50 -	■	■	□	500	510
SP-SL-84 L 55 -	■	■	□	550	560

Sponde Metalliche SLIM ammortizzate - H.116
SLIM Metal Boxes with Soft-Closing - H.116

Specifiche

Estrazione: Totale sincronizzata
Chiusura: Ammortizzata
Portata: 45 Kg
Durata: Oltre 50.000 cicli
Finitura guida: Zincata

Specifications

Extention: Full Synchronized
Closing: Soft
Load Rating: 45 Kg
Cycling: Over 50.000 times
Slide Finishing: Galvanized

Finitura sponda Slim box finishing

Grigio antracite	Dark grey
Grigio chiaro	Light grey
Bianco	White

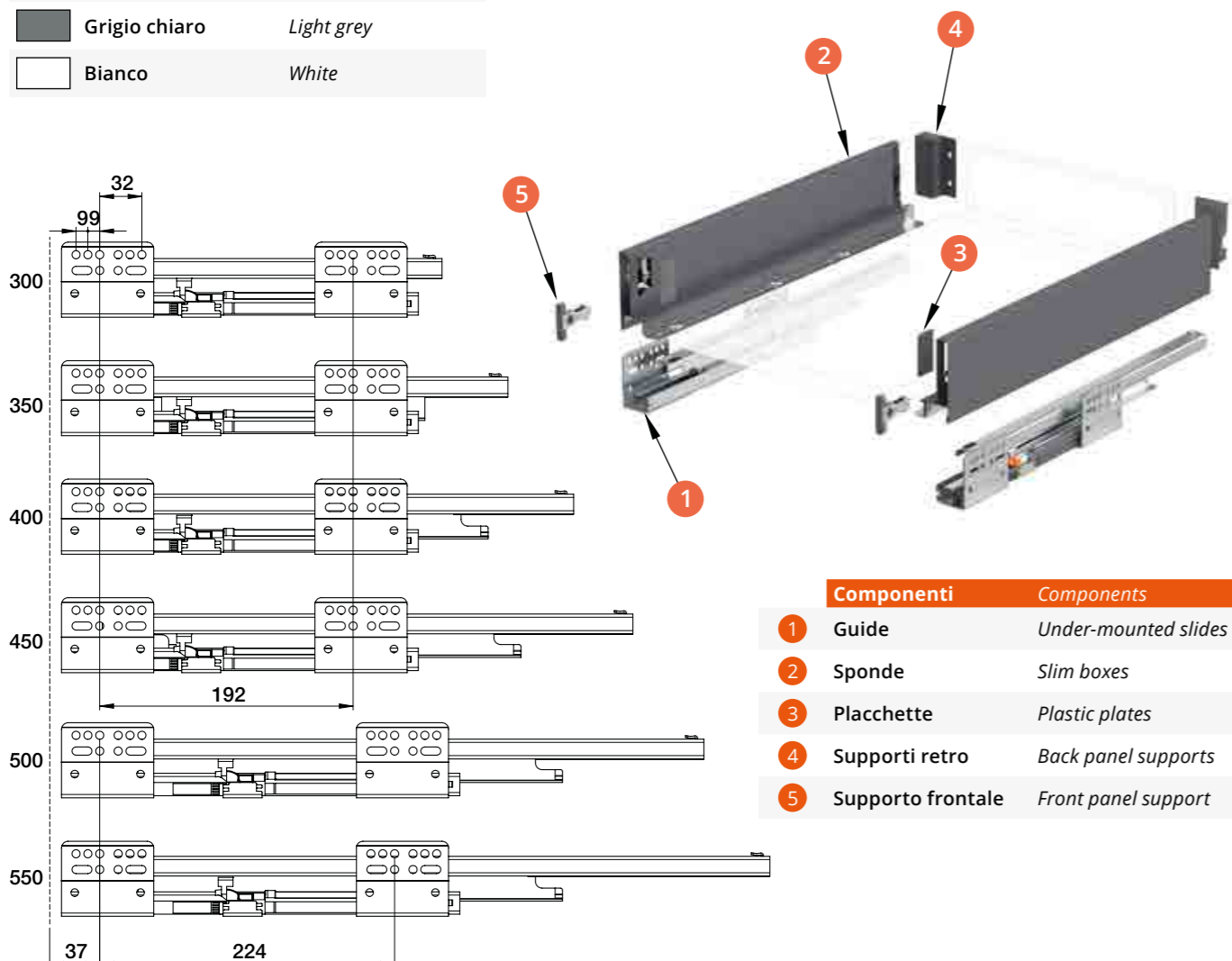

Componenti Components

1	Guide	Under-mounted slides
2	Sponde	Slim boxes
3	Placchette	Plastic plates
4	Supporti retro	Back panel supports
5	Supporto frontale	Front panel support

Dimensioni per montaggio frontale
Drawer front panel assembling diagram

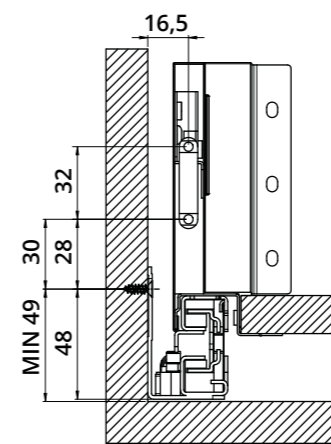

Vista frontale / Front view

Dimensioni ingombro cassetto e retro
Drawer and back panel overall dimensions

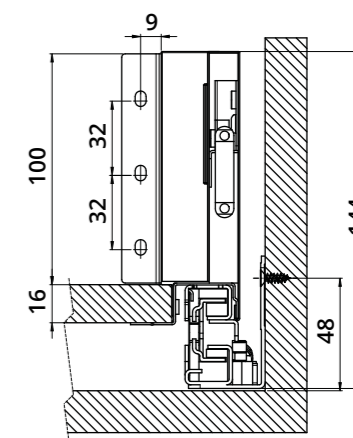

Vista retro / Back view

Dimensioni fondo e retro
Bottom and back panel dimensions

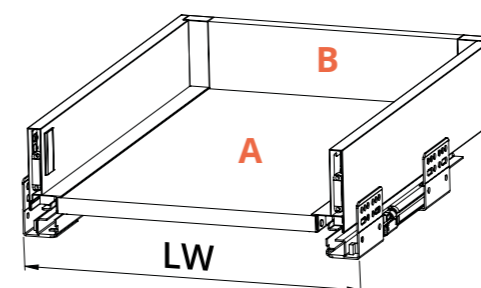

LW=Larghezza interna mobile
LW=Cabinet inner width

Fondo / Bottom panel

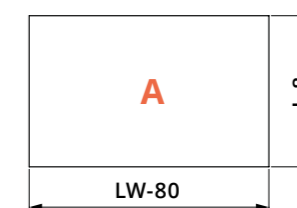

Retro / Back panel

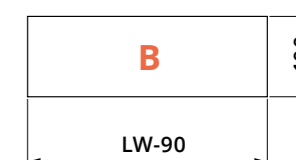

Pannello spessore: 16 mm
Panel thickness: 16 mm

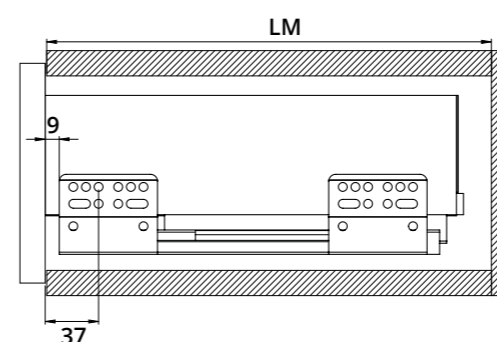

Foratura fianco con frontale a battuta
Side panel hole drilling with outer drawer front

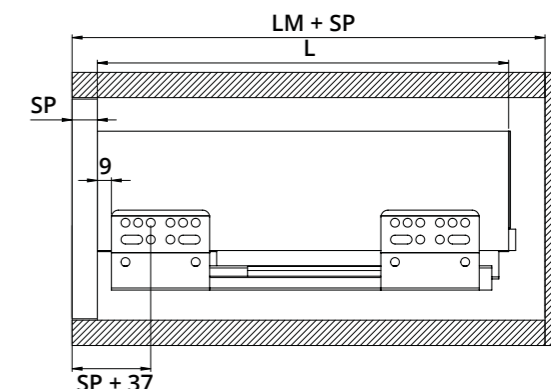

Foratura fianco con frontale interno
Side panel hole drilling with inner drawer front

Codice Code	Finitura sponda Slim box finishing			L	LM
SP-SL-116 L 30 -	■	■	□	300	310
SP-SL-116 L 35 -	■	■	□	350	360
SP-SL-116 L 40 -	■	■	□	400	410
SP-SL-116 L 45 -	■	■	□	450	460
SP-SL-116 L 50 -	■	■	□	500	510
SP-SL-116 L 55 -	■	■	□	550	560

Sponde Metalliche SLIM ammortizzate - H.167
SLIM Metal Boxes with Soft-Closing - H.167

Specifiche

Estrazione: Totale sincronizzata
Chiusura: Ammortizzata
Portata: 45 Kg
Durata: Oltre 50.000 cicli
Finitura guida: Zincata

Specifications

Extention: Full Synchronized
Closing: Soft
Load Rating: 45 Kg
Cycling: Over 50.000 times
Slide Finishing: Galvanized

Finitura sponda Slim box finishing

■ Grigio antracite	Dark grey
■ Grigio chiaro	Light grey
□ Bianco	White

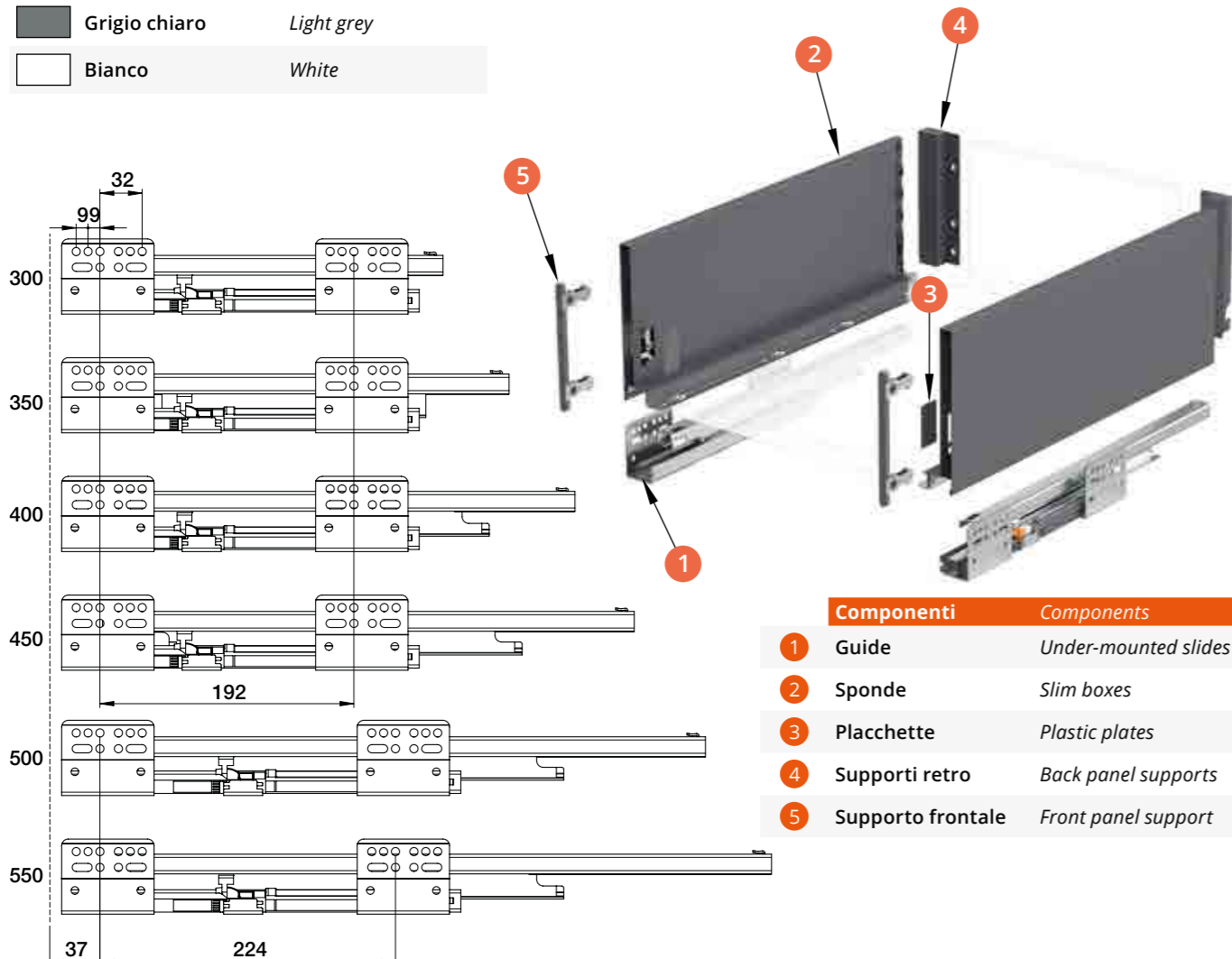

Componenti Components

- | | | |
|---|-------------------|----------------------|
| 1 | Guide | Under-mounted slides |
| 2 | Sponde | Slim boxes |
| 3 | Placchette | Plastic plates |
| 4 | Supporti retro | Back panel supports |
| 5 | Supporto frontale | Front panel support |

Dimensioni per montaggio frontale
Drawer front panel assembling diagram

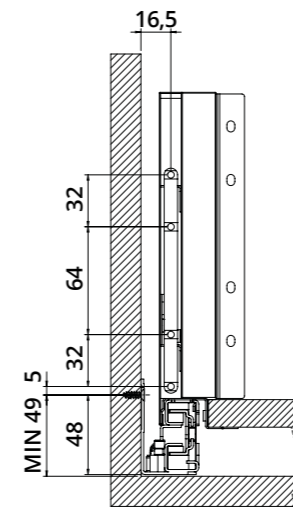

Vista frontale / Front view

Dimensioni ingombro cassetto e retro
Drawer and back panel overall dimensions

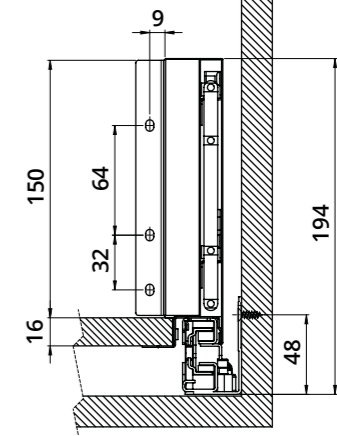

Vista retro / Back view

Dimensioni fondo e retro
Bottom and back panel dimensions

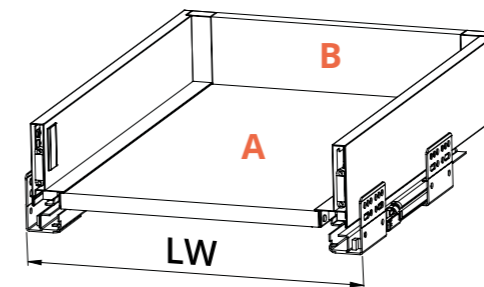

LW=Larghezza interna mobile
LW=Cabinet inner width

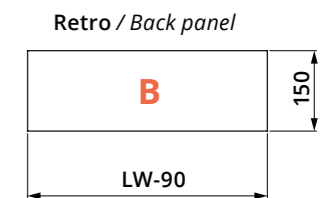
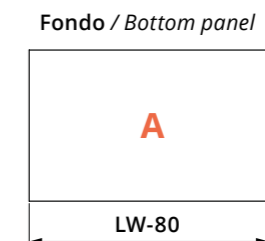

Pannello spessore: 16 mm
Panel thickness: 16 mm

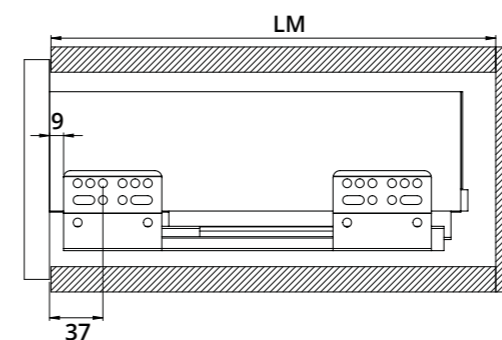

Foratura fianco con frontale a battuta
Side panel hole drilling with outer drawer front

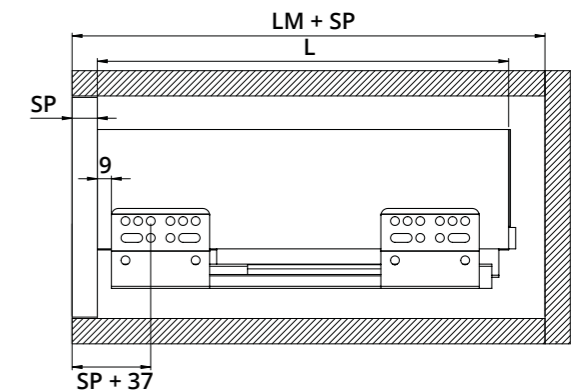

Foratura fianco con frontale interno
Side panel hole drilling with inner drawer front

Codice Code	Finitura sponda Slim box finishing			L	LM
SP-SL-167 L 30 -	■	■	□	300	310
SP-SL-167 L 35 -	■	■	□	350	360
SP-SL-167 L 40 -	■	■	□	400	410
SP-SL-167 L 45 -	■	■	□	450	460
SP-SL-167 L 50 -	■	■	□	500	510
SP-SL-167 L 55 -	■	■	□	550	560

Sponde Metalliche SLIM ammortizzate - H.199
SLIM Metal Boxes with Soft-Closing - H.199

Specifiche

Estrazione: Totale sincronizzata
Chiusura: Ammortizzata
Portata: 45 Kg
Durata: Oltre 50.000 cicli
Finitura guida: Zincata

Specifications

Extention: Full Synchronized
Closing: Soft
Load Rating: 45 Kg
Cycling: Over 50.000 times
Slide Finishing: Galvanized

Finitura sponda Slim box finishing

	Grigio antracite	Dark grey
	Grigio chiaro	Light grey
	Bianco	White

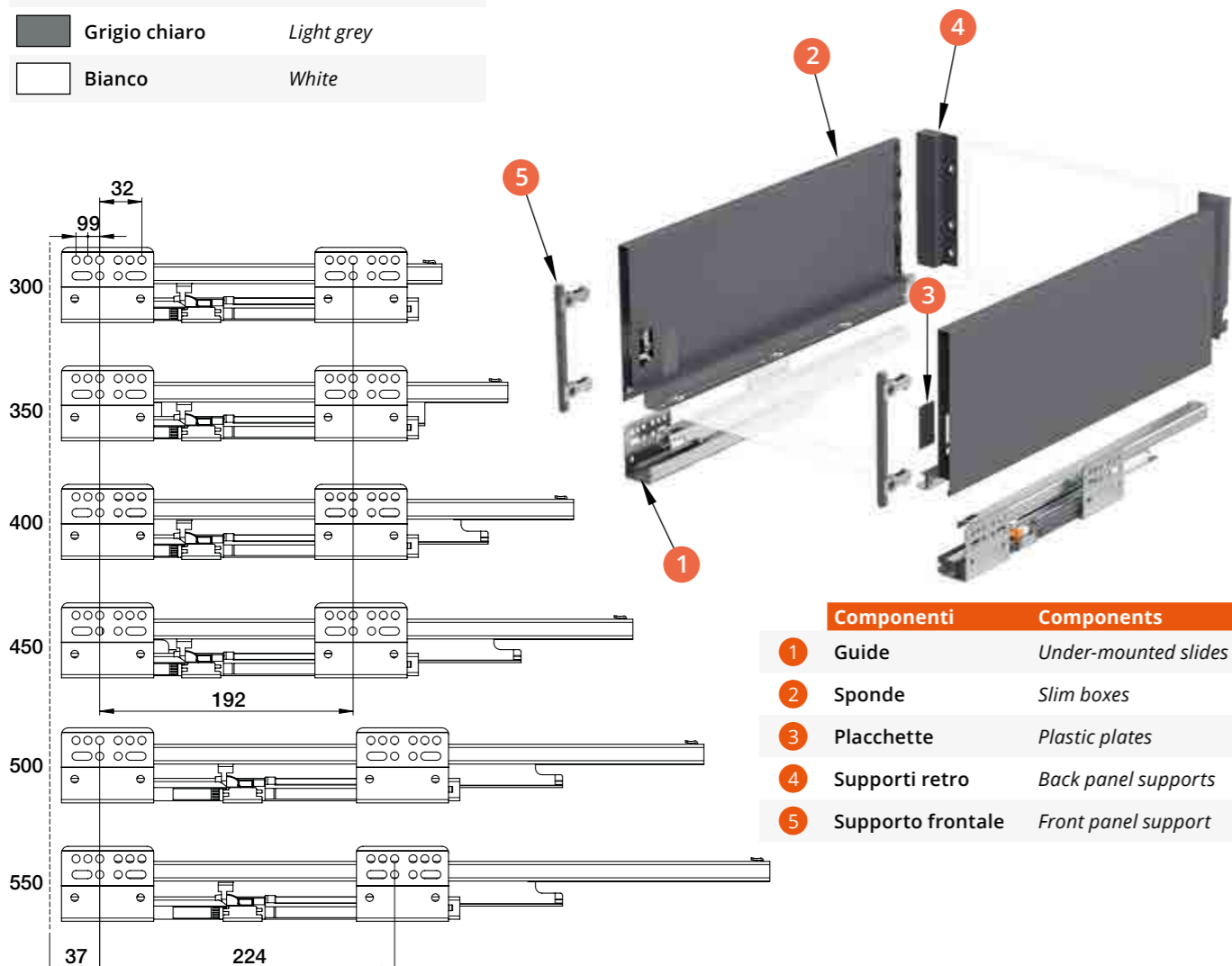

Componenti	Components
1 Guide	Under-mounted slides
2 Sponde	Slim boxes
3 Placchette	Plastic plates
4 Supporti retro	Back panel supports
5 Supporto frontale	Front panel support

Dimensioni per montaggio frontale
Drawer front panel assembling diagram

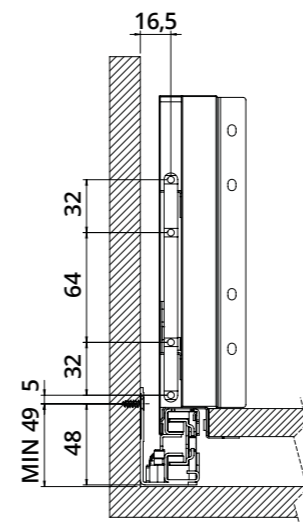

Vista frontale / Front view

Dimensioni ingombro cassetto e retro
Drawer and back panel overall dimensions

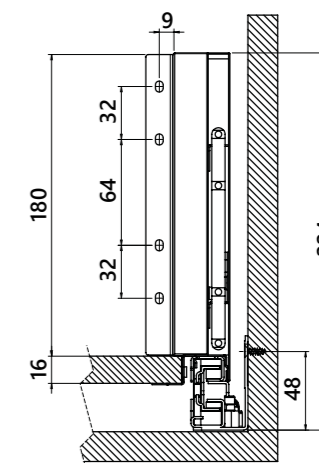

Vista retro / Back view

Bottom and back panel dimensions

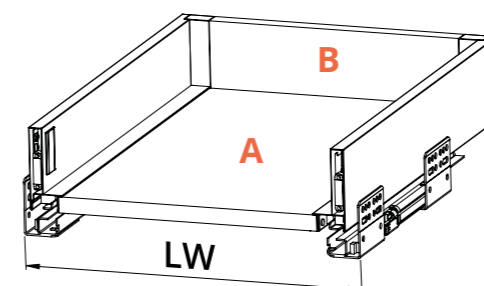

LW=Larghezza interna mobile
LW=Cabinet inner width

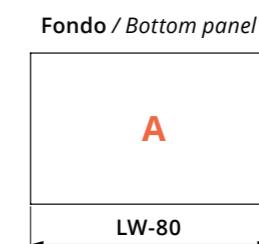

Fondo / Bottom panel

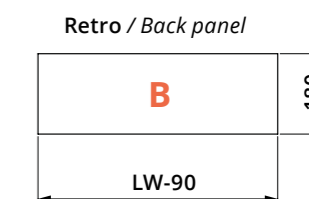

Retro / Back panel

Pannello spessore: 16 mm
Panel thickness: 16 mm

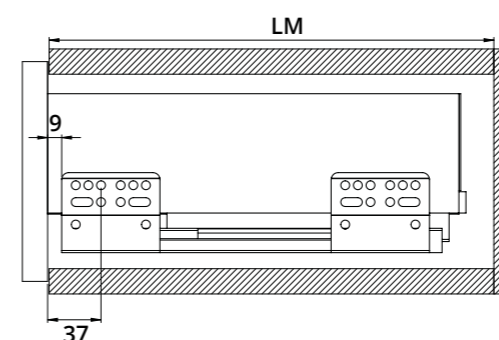

Foratura fianco con frontale a battuta
Side panel hole drilling with outer drawer front

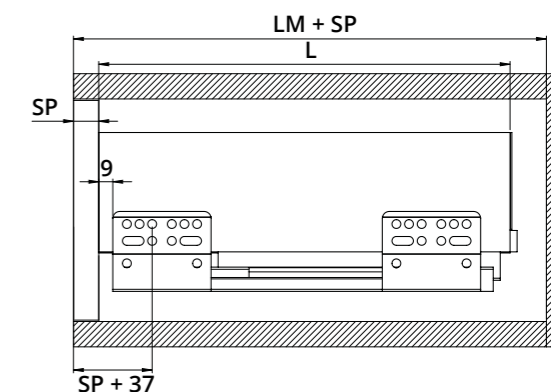

Foratura fianco con frontale interno
Side panel hole drilling with inner drawer front

Codice Code	Finitura sponda Slim box finishing	L	LM
SP-SL-199 L 30 -		300	310
SP-SL-199 L 35 -		350	360
SP-SL-199 L 40 -		400	410
SP-SL-199 L 45 -		450	460
SP-SL-199 L 50 -		500	510
SP-SL-199 L 55 -		550	560